

M20-32 Processor Module

- IEEE 1588 slave controller

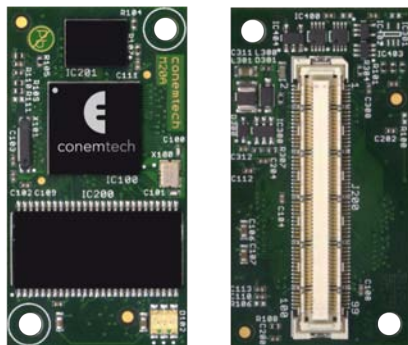

Key Features

- Full IEEE 1588-2008 Ordinary Clock implementation
- Configurable Loop Control for complex multi-hop and congested networks
- Based on the Conemtech Processor C32 with Hardware Timestamping
- Dual Ethernet Interfaces
- Configurable oscillator interface for extended holdover
- FX100 connector with 24x45 mm projected board space.

Applications

- Base Station synchronization in packet based networks
- Smartgrid synchronization interface for Distributed Energy Resources (DERs); new generation energy sources like windmills and solar panels etc
- Industrial Automation local time provider for remote I/O devices.

Description

The M20 represents a small form factor for processor modules from Conemtech. Containing one of the C3-family of microcontrollers from Conemtech, the module constitutes a reference design for how an efficient embedded system could be designed. It offers OEM customers a basis for evaluation of the Conemtech platform for embedded control and enables the building of functional prototypes and development of application software.

With its small footprint and 100-signal connector this production quality grade product can also be used in final customer products. The M20-32 module is a good start-

System Features

General Network Interface

- 2x RMII ports
- Integrated TCP/IP stack

PTP

- Hardware Timestamp Engine (TSE)
- One and Two-step clock modes

ing point for a low-risk development. The module offers full access to all I/O interfaces of the processor. The module contains SDRAM and serial flash in addition to the processor. Using the module, the customer PCB can be a low-density 2-layer board.

The M20-32 is provided with the IEEE 1588-2008 protocol firmware for an Ordinary Clock implementation as master and slave clock. The unique processor ability to process timestamps on gate level has been used to make a high accuracy 1588 clock.

- Fast Best Master Clock algorithm
- Master-slave (full) and slave-only state machines
- Delay request-response and peer delay mechanisms
- Asymmetry correction
- Configurable loop control for applications in complex networks
- Management messages.



M20-32 Processor Module

- IEEE 1588 slave controller

Data sheet

Ethernet

- Full- and half-duplex operation at 10/100 Mbit/s
- Up to 18.5 Mbit/s sustained UDP stack throughput
- Supports 60 Mbit/s data paths

PTP Slave

- Supports one-step and two-step masters
- Input sync rate: up to 128 Hz
- Accuracy: up to +/-50 ns *)
- Holdover: tbd
- Extended holdover by flexible oscillator interface

Input synchronization interfaces

- PTP: over Ethernet or UDP/IPv4 (L2 or L3)

Output synchronization interfaces

- PTP: over Ethernet or UDP/IPv4 (L2 or L3)
- FREQ-out: equal to FREQ-in
- PPS-out: up to 2 kHz with 1us resolution

- TOD-out: TTL, 4800/9600 bps, via dedicated pin up to 115200 bps via serial port

ToD Output Formats

- NMEA
- YYYY-MM-DD HH:MM:SS
- China Mobile (optional)

Other features

- DHCP client
- FTP server
- Telnet server
- Serial terminal
- Remote firmware upgrade
- Configurable in every aspect via command-line interface (over Telnet or Terminal).

*) depending on master quality and network configuration

Programming

The M20-32 requires no on-module programming if inserted as a subsystem to an existing processor. The existing processor can communicate by implementing a set of HMI like commands. A generic use of precise time can then be made by use of the signal presentation on the PPS, ToD and reference frequency port pins on the module.

When inserted in the Ethernet transmission chain, the M20-32 can leverage the components ability to manage the Precise Time Protocol, sharing the same IP address as the local network processor up to 60 Mbit/s. This is done while running the time and synchronization stack for IEEE 1588 up to the standards maximum sync rate 128 per second.

Advanced users can use the C-programming environment of the Developer IDE software. A top level system API enables programmers to add applications alongside the application for the disciplined clock and make use of the precise time.

Block Diagram

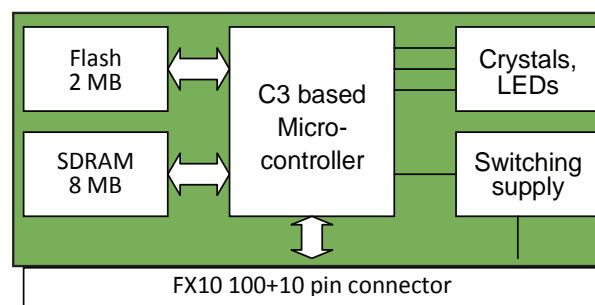

Even more advanced users can add functionality to replace the original local processor. Besides the PTP engine several other API's, like the POSIX RTOS are available for system programming.

Technical Specifications M20-32

- High Performance Conemtech C3 Core @ 167 MHz
- 8MB SDRAM and 2MB Flash
- Analog ports: dual DAC, eight channel ADC
- Supply Voltage 4 - 25V unregulated or 3.3V regulated
- Small outline Module: 24x 45 x 6 mm
- Rugged FX10 receptacle with 100 signals +10 ground
- Operating temperature 0 – 70 °C (-40 to +85 °C optional)
- RoHS compliant.

Ordering Information

M20-32 Processor Module based on the C32

other products

- P40 Assembled and Tested OEM Board (incl. M20)
- DK4 Development and Evaluation Kit for the P40 and M20 products

Conemtech may make changes to specifications and product descriptions in this document at any time, without notice.

9.10