

M50-32 - Packet Network Sync Module

- IEEE 1588 slave controller

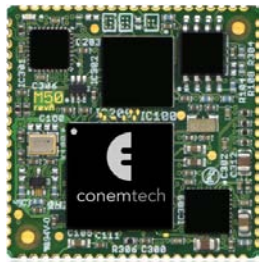

Applications

- Packet Network Time and Frequency Synchronization Controller
- Smartgrid synchronization interface for Distributed Energy Resources (DERs); new generation energy sources like windmills and solar panels etc
- Industrial Automation local time provider for remote I/O devices.

Key Features

- Full IEEE 1588-2008 ordinary clock implementation
- Configurable Loop control for complex multi-hop and congested networks
- Based on the Conemtech C32 Processor with hardware timestamping
- Dual Ethernet interfaces
- Contains the full network interface up to transformer
- Configurable oscillator interface for extended holdover
- Surface Mounted LCC device on a less than 30x30 mm board space
- Max 630 mW power consumption
- RoHS compliant.

Description

The new M50 form factor for the Conemtech processor with a Precise Time Protocol (PTP) system on-chip dramatically reduces the cost, power budget and board space for time and frequency synchronization. The module embeds a platform including real-time operating system, flash file system, communication stacks and more. A validated IEEE 1588 - 2008 protocol compliant stack is integrated. An advanced loop control manages complex network topologies and loads.

The M50-32 is an optimized design based on the C32 controller from Conemtech. Designers can fit the miniature sub-system containing a complete IEEE 1588-2008 ordinary clock implementation on a 30x30 mm board space. Its application is as a standard Fast Ethernet Network Interface module replacing the existing PHY and adds functionality to

System Features

General Network Interface

- 1x Fast Ethernet, 1x RMII ports
- Integrated TCP/IP stack

PTP

- Hardware Timestamp Engine (TSE)
- One and Two-step clock modes
- Fast Best Master Clock algorithm

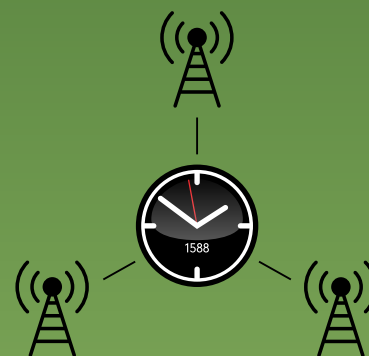

replace a local oscillator by providing packet based timing.

The M50-32 shortens time to market for products requiring IEEE 1588-2008 functionality. It reduces the cost of synchronization while not only replacing the PHY and its peripheral components, but also the local oscillator and real-time clock. The M50 can be integrated without the need for host programming. If you want to save costs even more, there is application space on the module to relocate the complete host functionality to the module.

The DK5 kit delivers the complete development environment for the M50 modules. Install the PC based software and connect the M50 based P50 via a USB cable. Your IEEE 1588-2008 master or slave is ready to go in minutes.

- Master-slave (full) and slave-only state machines
- Delay request-response and peer delay mechanisms
- Asymmetry correction
- Configurable loop control for applications in complex networks
- Management messages.

M50-32 - Packet Network Sync Module

- IEEE 1588 slave controller

Data sheet

Ethernet

- Full- and half-duplex operation at 10/100 Mbit/s
- Up to 18.5 Mbit/s sustained UDP stack throughput
- Supports 60 Mbit/s data paths

PTP Slave

- Supports one-step and two-step masters
- Input sync rate: up to 128 Hz
- Accuracy: up to +/-50 ns *)
- Holdover: tbd
- Extended holdover by flexible oscillator interface

Input synchronization interfaces

- PTP: over Ethernet or UDP/IPv4 (L2 or L3)

Output synchronization interfaces

- PTP: over Ethernet or UDP/IPv4 (L2 or L3)
- FREQ-out: 5/10/20/25 MHz
- PPS-out: up to 2 kHz with 1 us resolution

- TOD-out: TTL, 4800/9600 bps, via dedicated pin up to 115200 bps via serial port

ToD Output Format

- NMEA
- YYYY-MM-DD HH:MM:SS
- China Mobile (optional)

Other features

- DHCP client
- FTP server
- TELNET server
- Serial terminal
- Remote firmware upgrade
- Configurable in every aspect via command-line interface (over Telnet or Terminal)

*) depending on master quality and network configuration

Programming

The M50-32 requires no on-module programming if inserted as a subsystem to an existing processor. The existing processor can communicate by implementing a set of HMI like commands. A generic use of precise time can then be made by use of the signal presentation on the PPS, ToD and reference frequency port pins on the module.

When inserted in the Ethernet transmission chain, the M50-32 can leverage the components ability to manage the Precise Time Protocol, sharing the same IP address as the local network processor up to 60 Mbit/s. This is done while running the time and synchronization stack for IEEE 1588 up to the standards maximum sync rate 128 per second.

Advanced users can choose the C-programming environment of the Developer IDE software. A top level system API enables programmers to add applications alongside the application for the disciplined clock and make use of the

Technical Specifications

- High Performance Conemtech C3 Core @ 150 MHz
- Supply Voltage 3.3V +/-10%
- Max power consumption at 150 MHz: 630 mW *)
- Package LCC84 29.2 x 29.2 x 3.8 mm
- Operating temperature 0 – 70 °C (-40 to +85 °C optional)
- RoHS compliant.

*) In-system power consumption when running 128 sync messages and 64 delay requests per second. The processor uses less than 10% of this and requires no extra cooling.

Block Diagram

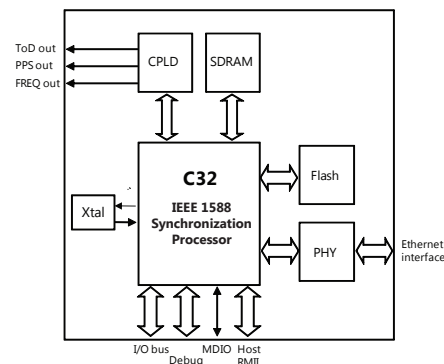

precise time. Even more advanced users can add functionality to replace the original local processor. Besides the PTP engine several other API's, like the POSIX RTOS are available for system programming.

Ordering Information

M50-32 Processor Module based on the C32 other products:

- P50 Assembled and Tested OEM Board (incl. M50)
- DK5 Development and Evaluation Kit for the P50 and M50 products

Conemtech may make changes to specifications and product descriptions in this document at any time, without notice.

9.10